

# **GAS CONVERSION KIT INSTALLATION INSTRUCTIONS**

**These instructions apply to the following gas conversion kits:**

**8262937**

**8262938**

**8262939**

**8262940**

**8262941**

**8262942**

**8262943**

**8262944**

## **WARNING**

**This conversion kit shall be installed by a qualified service agency in accordance with the manufacturer's instructions and all applicable codes and requirements of the authority having jurisdiction. If the information in these instructions is not followed exactly, a fire, an explosion or production of carbon monoxide may result causing property damage, personal injury or loss of life. The qualified service agency is responsible for the proper installation of this kit. The installation is not proper and complete until the operation of the converted appliance is checked as specified in the manufacturer's instructions supplied with the kit.**

These instructions apply to the kits listed in the tables below. ***Before beginning installation, verify the kit number on the package is correct for the intended fryer.***

### Propane to Natural Gas Conversion Kits

<b>Kit: 8262937</b>		<b>Converts: CE HD60, HD63, HD65 NAT. TO PRO</b>
8102400	2	PILOT ORFICE
8102939	5	HD ORIFICE, 1.40MM (#54)
8196788	1	INSTRUCTIONS
8022144	1	LABEL,CONVERSION DATE ENG/FCAN
8022751	1	LABEL,HD60/65 FROM NAT TO PRO
8071848	1	KIT, NAT TO PRO GAS CONVERSION

<b>Kit: 8262938</b>		<b>Converts: CE HD60, HD63, HD65 PRO TO NAT.</b>
8100811	2	PILOT ORFICE
8102938	5	HD ORIFICE, 2.26MM (#43)
8196788	1	INSTRUCTIONS
8022144	1	LABEL,CONVERSION DATE ENG/FCAN
8022752	1	LABEL,HD60/65 FROM PRO TO NAT
8071847	1	KIT, PRO TO NAT GAS CONVERSION

<b>Kit: 8262939</b>		<b>Converts: CE HD50 NAT. TO PRO</b>
8102400	1	PILOT ORFICE
8102939	4	HD ORIFICE, 1.40MM (#54)
8196788	1	INSTRUCTIONS
8022144	1	LABEL,CONVERSION DATE ENG/FCAN
8022753	1	LABEL,HD50 FROM NAT TO PRO
8071848	1	KIT, NAT TO PRO GAS CONVERSION

<b>Kit: 8262940</b>		<b>Converts: CE HD50 PRO TO NAT.</b>
8100811	1	PILOT ORFICE
8102938	4	HD ORIFICE, 2.26MM (#43)
8196788	1	INSTRUCTIONS
8022144	1	LABEL,CONVERSION DATE ENG/FCAN
8022754	1	LABEL,HD50 FROM PRO TO NAT
8071847	1	KIT, PRO TO NAT GAS CONVERSION

### Natural Gas to Propane Conversion Kits

<b>Kit: 8262941</b>		<b>Converts: CE HD60, HD63, HD65 Thermatron NAT. TO PRO</b>
8102400	2	PILOT ORFICE
8102939	5	HD ORIFICE, 1.40MM (#54)
8196788	1	INSTRUCTIONS
8022144	1	LABEL,CONVERSION DATE ENG/FCAN
8022755	1	LABEL,HD60/65 TMT NAT TO PRO
8071848	1	KIT, NAT TO PRO GAS CONVERSION

<b>Kit: 8262942</b>		<b>Converts: CE HD60, HD63, HD65 Thermatron PRO TO NAT.</b>
8100811	2	PILOT ORFICE
8102938	5	HD ORIFICE, 2.26MM (#43)
8196788	1	INSTRUCTIONS
8022144	1	LABEL,CONVERSION DATE ENG/FCAN
8022756	1	LABEL,HD60/65 TMT PRO TO NAT
8071847	1	KIT, PRO TO NAT GAS CONVERSION

<b>Kit: 8262943</b>		<b>Converts: CE HD50 Thermatron NAT. TO PRO</b>
8102400	1	PILOT ORFICE
8102939	5	HD ORIFICE, 1.40MM (#54)
8196788	1	INSTRUCTIONS
8022144	1	LABEL,CONVERSION DATE ENG/FCAN
8022757	1	LABEL,HD50 TMT NAT TO PRO
8071848	1	KIT, NAT TO PRO GAS CONVERSION

<b>Kit: 8262944</b>		<b>Converts: CE HD50 Thermatron PRO TO NAT.</b>
8100811	1	PILOT ORFICE
8102938	4	HD ORIFICE, 2.26MM (#43)
8196788	1	INSTRUCTIONS
8022144	1	LABEL,CONVERSION DATE ENG/FCAN
8022758	1	LABEL,HD50 TMT PRO TO NAT
8071847	1	KIT, PRO TO NAT GAS CONVERSION

### CAUTION

**The gas supply shall be shut off prior to disconnecting the electrical power, before proceeding with the conversion.**

## Installation Instructions

1. Shut off the gas supply to the fryer and disconnect the fryer from the electrical power supply.
2. Remove the burner heat shield to expose the burner mounting bolts.
3. Loosen but do not remove the burner mounting bolts.
4. One at a time, lift the burners up and disengage them from the burner bracket, then lift them up and off the burner orifices.
5. Unscrew the existing burner orifices from the manifold and replace them with those in the kit.
6. Unscrew the gas tube from the pilot burner and carefully pull it away from the pilot burner.
7. The pilot orifice should drop out of the pilot hood. If it does not, gently pry it out.
8. Insert the replacement pilot orifice in the hood at approximately a 15° angle and reconnect the gas tube. See illustration on page 5.
9. Remove the trailing pilot, if present, and replaced with provided pilot.

10. Convert the gas valve regulator in accordance with the instructions furnished with the regulator conversion kit.
11. Reinstall the burners by slipping them over the burner orifices and engaging the mounting bolts in the keyhole slots in the mounting bracket. Tighten the mounting bolts.
12. Verify that the incoming gas pressure is in accordance with the appropriate table in the Installation and Operation Manual for the fryer being converted.
13. Open the gas supply to the fryer and check for leaks using a solution leak detection fluid applied to each connection in the fryer's gas supply system.
14. Turn off the gas supply to the fryer. Attach a manometer to the burner manifold pressure tap then reconnect the fryer to the electrical power supply.
15. Light the pilot in accordance with the instructions in the Installation and Operation Manual for the fryer being converted and verify that the pilot flame is approximately 1-inch long. If adjustment is necessary, remove the pilot flame adjustment screw cap on the gas valve and, using a small flat-tipped screwdriver, turn the adjustment screw counterclockwise to increase the length of the flame or clockwise to decrease it. Reinstall the cap when adjustments are completed.
16. Verify that there is cooking oil or water in the frypot. Place the gas valve in the ON position to light the burners. Verify that each burner lights and that the manifold pressure is in accordance with the appropriate table in the Installation and Operation Manual. Adjust the burner manifold pressure as required by turning the regulator adjustment screw clockwise to increase the pressure or counterclockwise to reduce the pressure.
17. Shut off the gas supply to the fryer. Disconnect the manometer and reinstall the pressure tap plug.
18. Light the fryer and verify proper operation in accordance with the instructions in the installation and operation manual.
19. Use a leak detection fluid to verify the pressure tap plug is not leaking.
20. On the inside of the fryer door, apply the conversion label as close to the data plate as possible and affix the conversion date label where it can best be seen.

# Typical Pilot, Trailer Pilot Configuration

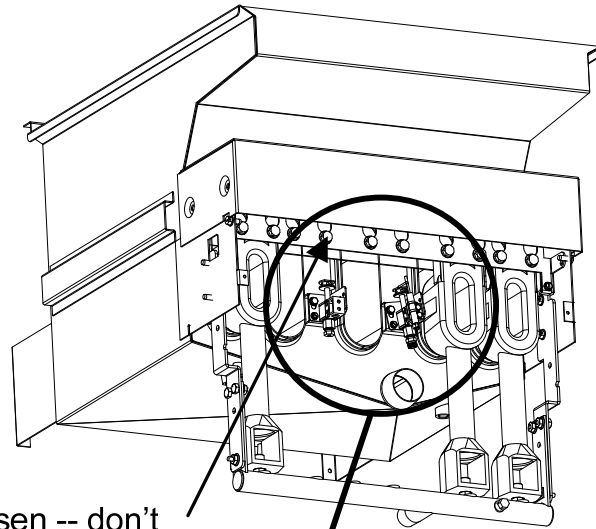

Loosen -- don't remove - burner bolts. The burners are lifted off the loosened bolts.

Remove burner heat shield to access burner bolts.

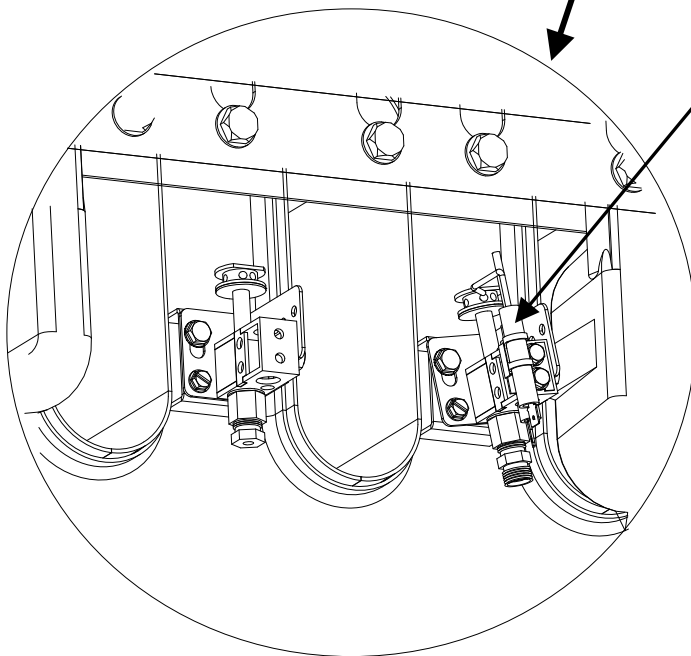
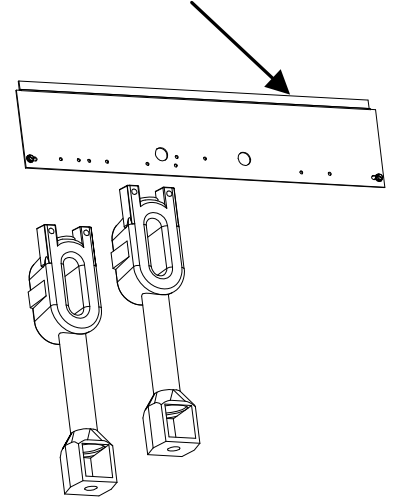

Pilot - Installed at an angle.

Orifice

